

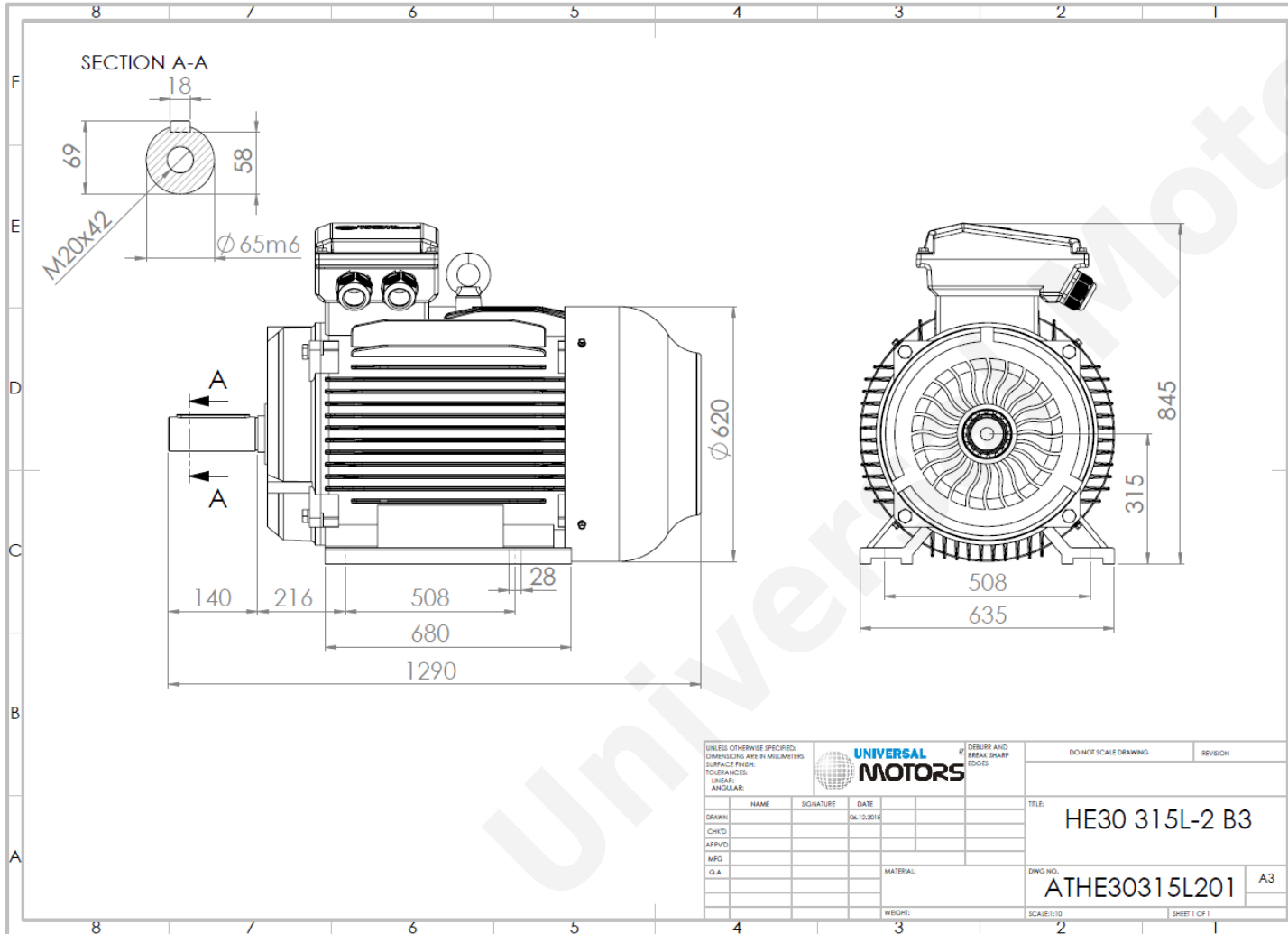

TECHNICAL DATA

Three Phase Electric Motors - Cast Iron Frame
 HE30 315L-2 IE2
 160 kW / 220 Cv
 2975 RPM



Motor type:	HE30 315L-2 IE2
Output:	160 kW / 220 Cv
Speed (min ⁻¹):	2975 RPM
Frequency:	50 Hz
Voltage:	400 V
Current:	268 A
Power factor (Cos ϕ):	0.91
Poles:	2
Insulation class:	F
Temperature rise Class:	B
Efficiency 50%:	94.0 %
Efficiency 75%:	95.1 %
Efficiency 100%:	94.8 %
Torque:	514 N.m
Tstarting/Tnominal:	2.0
Istarting/Inominal:	7.1
Tmaximum/Tnominal:	2.2
Noise:	81 Db(A)
Weight:	990 Kg
Bearing DE:	6317 C3
Bearing NDE:	6317 C3

Regime - S1

Altitude - 1000m

Environment Temperature - 40°C

CONTACTS:

UNIVERSAL MOTORS Tel: +351 252 299 080
 Rua de São Brás,745 Fax: +351 252 299 089
 4480-782 VILA DO CONDE Mail: geral@universalmotors.pt

* References applied only in the UK